

TECHNICAL INFORMATION SHEET



Description

Soundlay Foam is a cross-linked, closed cell polyolefin foam which is ideal as a low cost, resilient under-screed layer designed to reduce the transmission of impact sound through concrete floors. The foam contains EVA rubber cells to give improved acoustic performance and increased resistance to compression and creeping.

Soundlay Foam is available in a range of thicknesses giving a choice of impact sound insulation values.

Installation

Soundlay Foam as an underscreed solution for impact sound reduction on cast-in-situ, beam and block and precast plank flooring. The use of Soundlay Foam eliminates the need for separate flanking strips around the perimeter and for a waterproof membrane.

To install, cover the floor with Soundlay Foam, butting adjacent sheets and completely taping all joints. To ensure complete acoustic isolation of the screed, turn up the foam to at least 5mm above the intended screed surface around the full perimeter of the floor.

Installation Service

In addition to supply of this product CMS Danskinn Acoustic can provide a listing of competitively-priced approved installers that service anywhere in the UK. Use of this service ensures that installation is performed to the highest standards by tradesmen fully experienced in the specialist skills of fitting CMS Danskinn acoustic materials correctly. For further details contact our technical team on 01925 577711.

Advantages

- Easy and fast to install
- Easy to handle
- High elasticity for excellent impact sound attenuation
- Low water absorption avoids need for additional waterproof membrane
- Good compression set
- Highly resistant to creeping

Specification

| Property | | Value | Standard |
|---|-------------|--------------------------|--------------|
| Roll sizes | | 50m x 2m | |
| Standard thicknesses | | 5mm & 10mm | |
| Roll weight | | 33kg (10mm) 17kg (5mm) | |
| Density | | 25 - 33kg/m ³ | |
| Tensile strength (longitudinal) | | 0.34MPa | EN ISO 1798 |
| Tensile strength (transversal) | | 0.29MPa | EN ISO 1798 |
| Elongation at Break (longitudinal) | | 200% | EN ISO 1798 |
| Elongation at Break (transversal) | | 210% | EN ISO 1798 |
| Compression stress strain 10% | | 16kPa | ISO 3386/1 |
| Compression stress strain 25% | | 36kPa | ISO 3386/1 |
| Compression stress strain 50% | | 95kPa | ISO 3386/1 |
| Compression set 25% 22h, 23 °C, 0.5h | | 19% | EN ISO 1856 |
| Compression set 25% 22h, 23 °C, 24h | | 11% | EN ISO 1856 |
| Compression set 50% 22h, 23 °C, 0.5h | | 43% | EN ISO 1856 |
| Compression set 50% 22h, 23 °C, 24h | | 32% | EN ISO 1856 |
| Operating temperature range | | -40 °C | DIN 51949 |
| Dimensional stability | | 80 °C | DIN 53431 |
| Thermal conductivity (λ) 0 °C | | 0.041 W/m °K | EN ISO 12667 |
| Thermal conductivity (λ) 20 °C | | 0.042 W/m °K | EN ISO 12667 |
| Water Vapour Permeability | | 0,00150 mg/m.h.Pa | EN ISO 12086 |
| Water absorption after 28 days | | 0.685% | EN ISO 12087 |
| Compression creep (under load 1kPa = 102kg/m ²) | at 30 days | 1,54% | EN 1606 |
| | at 1 year | 3,56% | EN 1606 |
| | at 5 years | 5,44% | EN 1606 |
| | at 10 years | 6,53% | EN 1606 |
| Dynamic stiffness s' (5mm) | | 87,2 MN/m ³ | EN 29052-1 |
| Dynamic stiffness s' (10mm) | | 57,7 MN/m ³ | EN 29052-1 |
| Impact sound insulation ΔL_{w}^* (5mm)** | | 21dB | EN ISO 140-8 |
| Impact sound insulation ΔR_{A}^* (10mm)*** | | 24dB | EN ISO 140-8 |
| Airbourne sound insulation (5mm) | | 6,0dBA | EN ISO 140-3 |
| Airbourne sound insulation (10mm) | | 7,5dBA | EN ISO 140-3 |
| Thickness reduction underload (5mm) | 0 Pa | 0,0% (Ei) | EN 12431 |
| | 250 Pa | 2,0% (dL) | EN 12431 |
| | 2 kPa | 6,1% (dF) | EN 12431 |
| | 50 kPa | 10,2% (dB) | EN 12431 |
| Thickness reduction underload (10mm) | 0 Pa | 0,0% (Ei) | UNE EN 12431 |
| | 250 Pa | 1,0% (dL) | UNE EN 12431 |
| | 2 kPa | 3,1% (dF) | UNE EN 12431 |
| | 50 kPa | 5,2% (dB) | UNE EN 12431 |

* RSD compliance requirement $\Delta L_w = 17$ dB minimum

** Floor construction 140mm concrete slab/5mm Soundlay Foam/65-70mm concrete screed

*** Floor construction 140mm concrete slab/10mm Soundlay Foam/65-70mm concrete screed/Parquet flooring system

Floating screed on beam and block floor

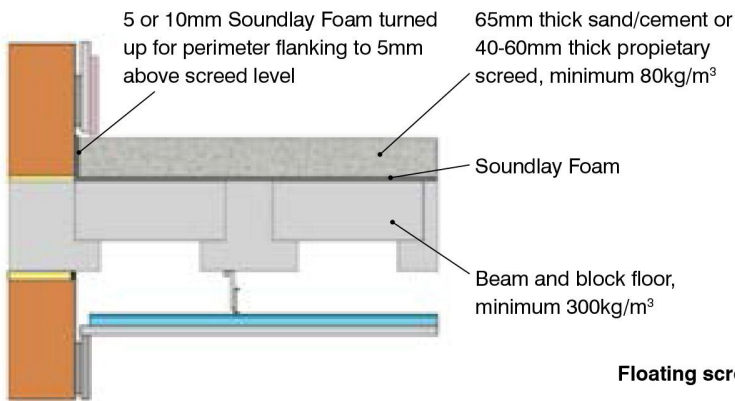

Floating screed on cast-in-situ concrete slab floor

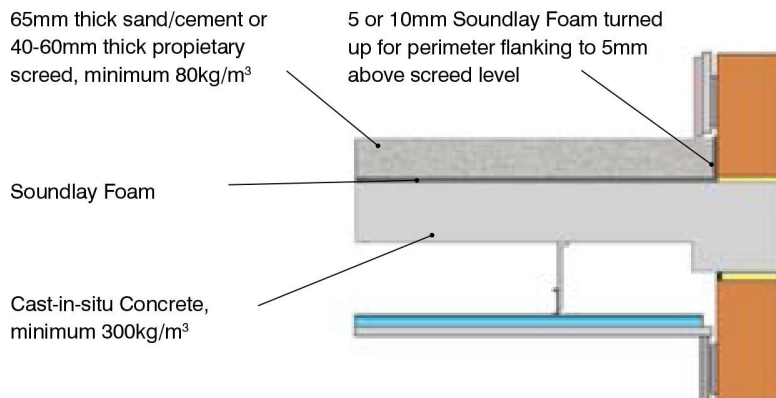

Floating screed on precast plank floor

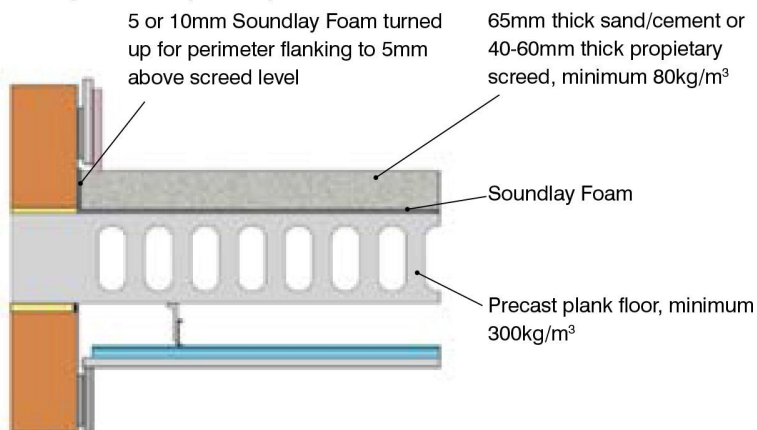

Floating screed on cast-in-situ concrete slab floor on hollow rib steeldeck

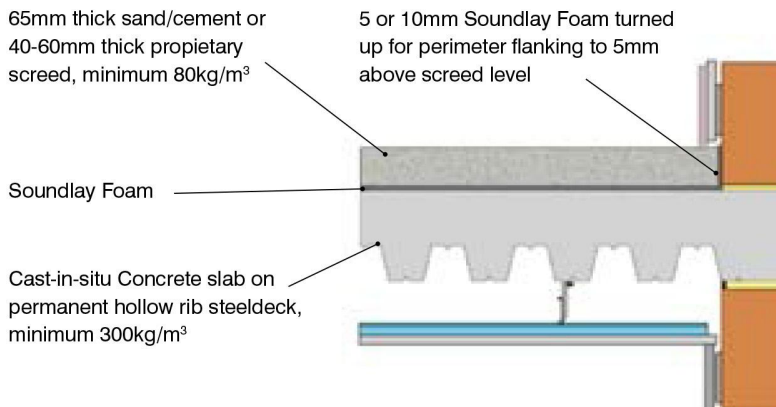

IMPORTANT: Directions for use are given for guidance only and are not intended to form part of any contract. They should be varied or adapted to suit your particular materials or conditions of use. Goods supplied by the company are made to approved standards from the highest quality raw materials but no warranty or guarantee is given as to their suitability for any particular purpose or application, and no liability is accepted for any loss or damage arising directly or indirectly from the use of the Company's products irrespective of any information given to us as to intended use of such products. It is therefore recommended that prospective users should test a sample of this product under their own conditions to satisfy themselves that the product is suitable for the purpose intended.